



CLOUD-100T/125T/150T

Instruction Manual



**READ THE MANUAL CAREFULLY BEFORE PROCEEDING WITH INSTALLATION WORKS.
COMPLIANCE WITH THE MANUAL REQUIREMENTS ENSURES RELIABLE OPERATION
AND LONG SERVICE LIFE OF THE UNIT.**

**KEEP THE USER'S MANUAL AVAILABLE AS LONG AS YOU USE THE UNIT. YOU MAY
NEED TO RE-READ THE INFORMATION ON THE PRODUCT SERVICING.**

PRODUCT INTRODUCTION

Thank you for choosing the CLOUD-100T/125T/150T extractor fan.

This model is designed for bathroom or kitchen ventilation, featuring an integrated Timer for efficient operation.

The fan is designed for easy installation in the bathroom, kitchen or utility room areas. It requires 100mm/125mm/150mm duct. Follow the instruction manual for proper setup, ensuring compliance with local electrical and building regulations. A qualified electrician is recommended for safe installation, especially in wet environments.

This product complies with UKCA requirements under the Electrical Equipment (Safety) Regulations 2016 and bears the UKCA mark. CE marking is also applicable for EU exports.

Electrical protection class according to IP rating against hazardous parts and water ingress is IP45 and it is suitable for installation in ZONE1 and ZONE2 with RCD protection. The fan is double insulated and does not require grounding.

SAFETY INSTRUCTIONS

1. Disconnect the main power supply before installation, wiring, or maintenance.
2. This appliance is not intended for use by persons (including children) with reduced physical, sensory, or mental capabilities unless supervised.
3. Do not install in locations where the fan may come into contact with water jets or be submerged.
4. Ensure the unit is mounted securely to avoid vibrations or noise.
5. The fan is Class II insulated and does not require an earth connection.
6. Use in warm, damp environments as per IEC standards; suitable for other climates with precautions.
7. Electrical protection class **IP45** and it is suitable for installation in ZONE1 and ZONE2 with RCD protection.

UNBOXING and OPENING

- To install the Cloud100T/125T/150T extractor fan, begin by carefully unboxing the unit and inspecting all components to ensure nothing is damaged or missing, as per the manufacturer's guidelines.
- Next, create a circular hole in the wall or ceiling with a slightly larger diameter than the model's \varnothing dimension (see technical table) to accommodate the fan's ducting and housing, making sure to select a suitable position that allows for proper ventilation and complies with local building regulations.
- Then, gently remove the first outer panel, labeled as number 1 in the accompanying drawing, by pulling it straight off from the fan body without applying excessive force.
- After that, locate and loosen the two diagonal screws that are highlighted in red on the drawing to detach the internal assembly.
- Once those screws are removed, carefully pull off the second inner panel to access the wiring terminals and mounting points inside the fan housing.
- Finally, connect the electrical wiring according to the detailed diagrams and instructions provided in the manual below this section—ensuring all connections are secure and performed by a qualified electrician for safety—before reassembling the protection grilles and panels in reverse order to complete the installation.

- **Please Note** that these units are not currently supported for a window installation. An additional window installation kit is required. Please contact AIR6 for further information.

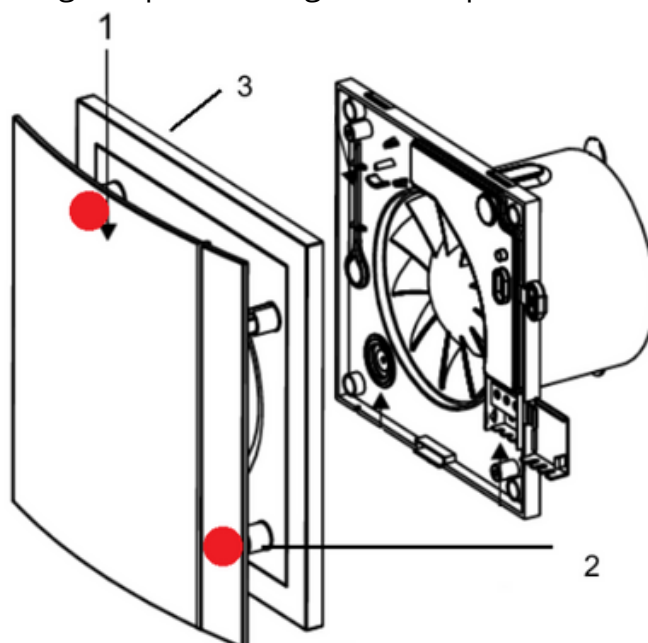

TECHNICAL INFORMATION

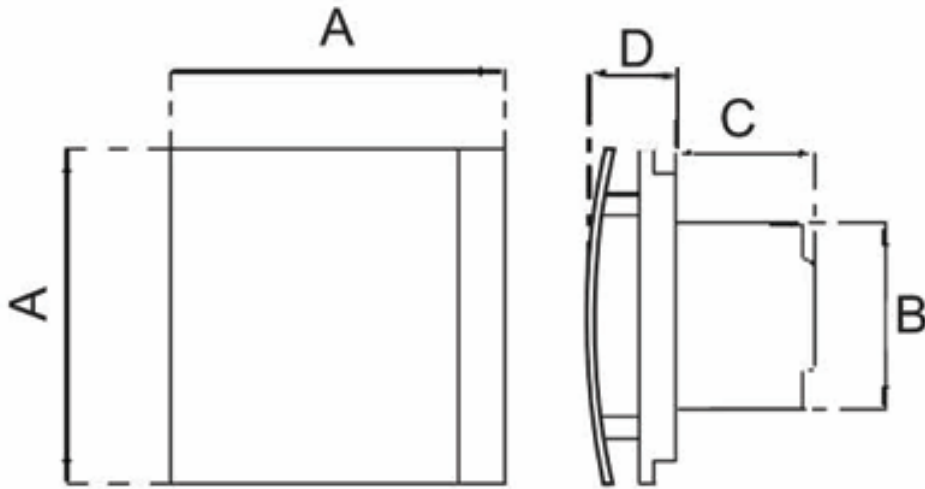

Model	A (mm)	ØB (mm)	C (mm)	D (mm)
Ø100	188	98.9	84.6	44.9
Ø125	210	122	88	55
Ø150	244	147	113	55

OTHER TECHNICAL DATA

Model	Voltage	Frequency	Input Power	Extract rate	Noise levels
Ø100	220-240V	50/60Hz	10W	95m ³ /h	30dB(A)
Ø125	220-240V	50/60Hz	12W	180m ³ /h	34dB(A)
Ø150	220-240V	50/60Hz	12W	230m ³ /h	35dB(A)

INSTALLATION & WIRING

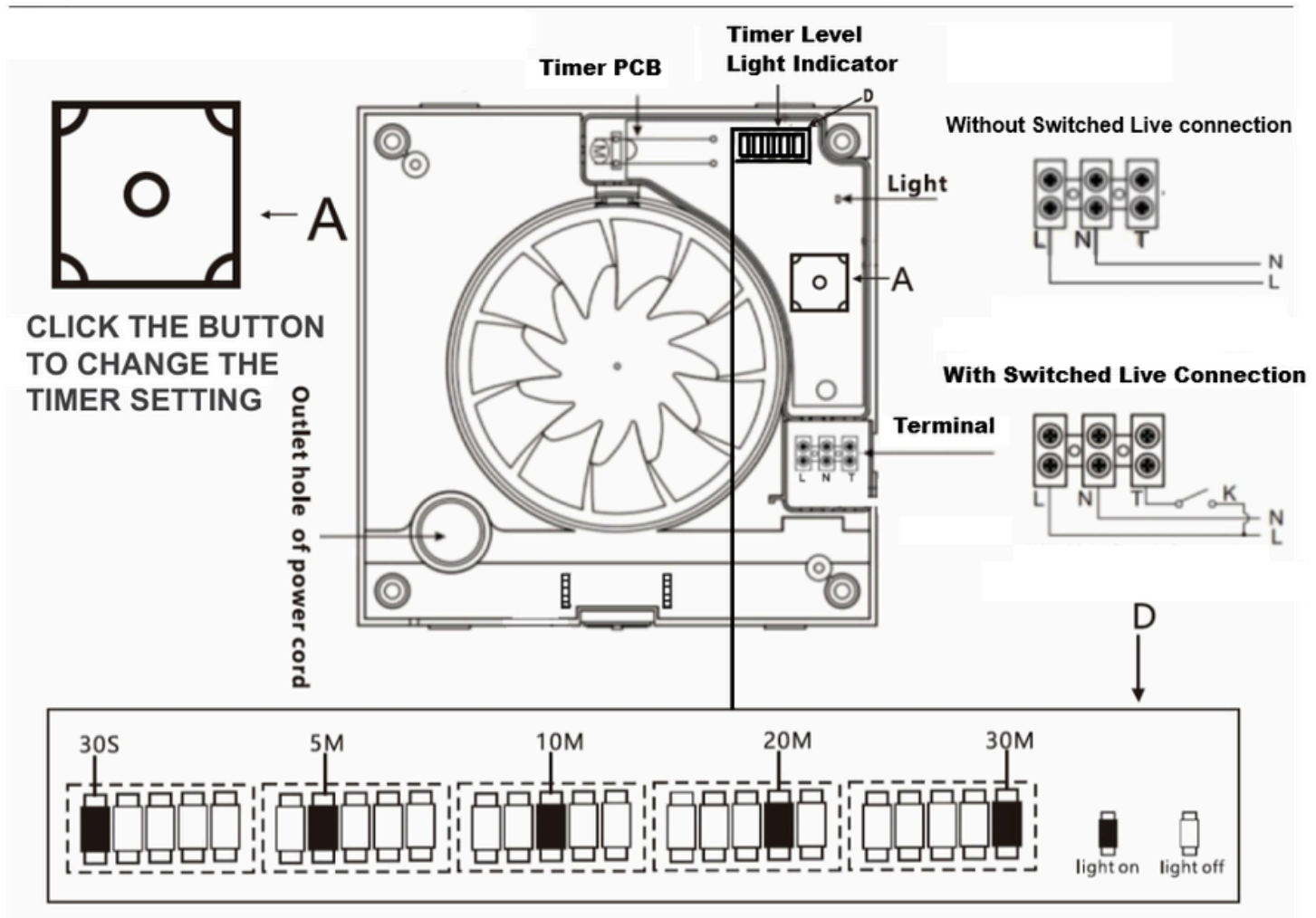

This model is provided with an adjustable over-run timer.

The timer allows the fan to continue to operate for the selected period of time after the light switch has been turned off. Figure above shows how to connect the fan with timer.

With Switched Live connection. Once the light switch has been turned off, the Extractor Fan will continue to operate for certain amount of time set and then shuts down. The Default Setting of the Timer is 5 minutes. To Change the "Run On" Time, CLICK the control knob (marked "A" in the drawing). The light indicator (fig. above) will show the selected setting.

Without Switched Live connection. This setup uses the timer as an overrun only after manual switch-on, not triggered by lights.

If there's no LS connection available and you have got 2 wires only L & N the extractor fan can still be used, together with the TIMER function. The extractor will simply turn on / off with the switch controlling it . But once it is turned ON by the switch the TIMER will activate which will shut down the extractor after the certain amount of time selected by TIMER setting

MAINTENANCE AND GUARANTEE TERMS

- Disconnect power before cleaning.
- Remove grille (1) and clean with a soft cloth and mild detergent. Do not use abrasives.
- Wipe impeller and housing; ensure no dust buildup.
- Check backdraft shutter annually.
- No lubrication needed (ball bearings are permanent).
- Clean every 6 months or as needed.
- Any other work than cleaning should be carried out by a qualified electrician.

GUARANTEE (TERMS OF GUARANTEE)

The 2-year warranty starts from the day of delivery and includes parts and labour for the first year. Remaining period covers replacement parts only. Warranty might be void if the extractor fan is modified, misused or disassembled not in accordance with this manual or regulations.

The product warranty applies to UK mainland.

Any damage must be inspected by the manufacturer or service agent.

Please read our AIR6 Cloud Series FAQ if you have any more questions.

To register the unit and to extend the warranty to 3 years please visit www.airsix.co.uk

Who should I contact for further support?

For additional questions or support, contact Air Six Ltd through their official website
www.airsix.co.uk

Email the AIR6 team at **info@airsix.co.uk**, or **support@bathroomfans.co.uk**

call **0800 699 0966** MON-FRI 8AM – 6PM, SAT 9AM-2PM

Sincerely, The AIR6 Team